

Editorial Manager(tm) for Computational Economics
Manuscript Draft

Manuscript Number:

Title: On the Selection of Adaptive Algorithms in ABM: A Computational-Equivalence Approach

Article Type: Special Issue Alkemade-poutre

Section/Category:

Keywords: Agent-Based Methodology, Agent Engineering, Computational Intelligence, Computational Equivalence, CE Lab

Corresponding Author: Professor Shu-Heng Chen, Ph. D.

Corresponding Author's Institution: National Chengchi University

First Author: Shu-Heng Chen, Ph.D

Order of Authors: Shu-Heng Chen, Ph.D; Shu-Heng Chen, Ph. D.

Manuscript Region of Origin:

Abstract: Agent-based Methodology (ABM) is becoming indispensable for the inter-disciplinary study of social and economic complex adaptive systems. The essence of ABM lies in the notion of autonomous agents whose behavior may evolve endogenously and can generate and mimic the corresponding complex system dynamics that the ABM is studying. Over the past decade, many Computational Intelligence (CI) methods have been applied to the design of autonomous agents, in particular, their adaptive schemes. This design issue is non-trivial since the chosen adaptive schemes usually have a profound impact on the generated system dynamics. Robert Lucas, one of the most influential modern economic theorists, has suggested using laboratories with human agents, also known as Experimental Economics, to help solve the selection issue. While this is a promising approach, laboratories used in the current experimental economics are not computationally equipped to meet the demands of the selection task. This paper attempts to materialize Lucas' suggestion by establishing a

laboratory where human subjects are equipped with the computational power that satisfies the computational equivalence condition.

On the Selection of Adaptive Algorithms in ABM: A Computational-Equivalence Approach

Shu-Heng Chen ^{a,*}, Chung-Ching Tai ^b

^a*AI-ECON Research Center, Department of Economics, National Chengchi University, Taipei, Taiwan 116*

^b*AI-ECON Research Center, Department of Economics, National Chengchi University, Taipei, Taiwan 116*

Abstract

Agent-based Methodology (ABM) is becoming indispensable for the inter-disciplinary study of social and economic complex adaptive systems. The essence of ABM lies in the notion of autonomous agents whose behavior may evolve endogenously and can generate and mimic the corresponding complex system dynamics that the ABM is studying. Over the past decade, many Computational Intelligence (CI) methods have been applied to the design of autonomous agents, in particular, their adaptive schemes. This design issue is non-trivial since the chosen adaptive schemes usually have a profound impact on the generated system dynamics. Robert Lucas, one of the most influential modern economic theorists, has suggested using laboratories with human agents, also known as Experimental Economics, to help solve the selection issue. While this is a promising approach, laboratories used in the current experimental economics are not computationally equipped to meet the demands of the selection task. This paper attempts to materialize Lucas' suggestion by establishing a laboratory where human subjects are equipped with the computational power that satisfies the *computational equivalence* condition.

Key words: Agent-Based Methodology, Agent Engineering, Computational Intelligence, Computational Equivalence, CE Lab,

* Corresponding author. Tel/fax: +886-2-29387308.
Email addresses: chchen@nccu.edu.tw (Shu-Heng Chen),
elliott@aiecon.org (Chung-Ching Tai).
URL: <http://www.aiecon.org> (Shu-Heng Chen).

1 Introduction

The use of agent-based simulation to study complex adaptive systems has become increasingly popular, and its significance has been well demonstrated by a series of recent conferences and journals exclusively devoted to this subject.¹ One of the major issues in agent-based simulation is *agent engineering*. Agent is a concept which has attracted a great deal of attention among economists in recent years. In earlier times, economists worked with the device of the agent, but largely without an explicit definition of it. It was the emergence of agent-based computational economics that pushed for a formal addressing of it,² and agent engineering represents a blueprint, a technical description, and a manifestation of the agent.

From a computer science viewpoint, a general definition of agent engineering is provided by Liu et al. [2001].

Agent engineering concerns the development of autonomous computational or physical entities capable of perceiving, reasoning, adapting, learning, cooperating and delegating in a dynamic environment.

Wooldridge & Jennings [1995] detail some of these possessed properties:

- *Autonomy*: agents can control their own actions and internal states to some extent and are able to operate without the direct intervention of humans or others;
- *Social ability*: agents can interact with other agents through agent-communication language;
- *Reactivity*: agents perceive their environment and can respond to it;
- *Pro-activeness*: more than simply responding to the environment, agents can also take the initiative and behave according to their goals.

The above general description applies well to the economic literature, such as

¹ Conferences exclusively devoted to this area include the Workshop on the Economics of Heterogeneous Interacting Agents (WEHIA), the Workshop on Agent-Based Approaches in Economic and Social Complex Systems (AESCS), the Conference on Agent-Based Models of Market Dynamics and Consumer Behaviour, and the Workshop on Multi-Agent Systems: Theory and Applications (MASTA), etc. Other conferences, such as Computing in Economics and Finance (CEF), the International Workshop on Computational Intelligence in Economics and Finance (CIEF), and the International Conference on Computational Intelligence, Robotics and Autonomous Systems (CIRAS), have also devoted quite a significant portion of their sessions and papers to this area. Journals which have a sharp focus in this area are the Journal of Artificial Societies and Social Simulation, the Journal of Economic Dynamics and Control, Journal of Economic Behavior and Organization, Nonlinear Dynamics, Psychology, and Life Sciences.

² A full review of the concept of the agent in economics is beyond the scope of this paper. The interested reader is referred to Lucas [1986], Holland & Miller [1991], Tesfatsion [1997], Chen [2001], Tesfatsion [2001], and LeBaron [2001].

to Tesfatsion [2001] for her discussion of autonomous adaptive agents, and to LeBaron [2001] for his discussion of financial agents.

In the agents literature, many have reported that the simulation results are highly dependent upon how agents are designed and how agents learn and adapt, i.e. *agent engineering does matter*. Hence, much work has been devoted to research on agent engineering. One important topic that agent engineering addresses is the *robustness* of agent-based simulation results. This is normally done by evaluating whether different learning algorithms used in the simulation would lead to different implications. While the famous *KISS principle*³ has provided a simple approach, e.g., *zero-intelligent random behavior*, for agent engineering (Duffy [2006]), other sophisticated approaches, e.g., *genetic algorithms*, are also very popular in the agents literature. In fact, many techniques within the field of *computational intelligence* have been used for agent engineering.⁴ Given such a wide variety of techniques, there is a great need for a guideline on how to select an appropriate technique for agent engineering.

Recently, there has been a guideline for selecting techniques based on empirical observations. This guideline leads to two possibilities. The first one uses data from field studies, surveys or censuses. Izumi & Ueda [2002], for example, use the evidence from interviews and questionnaires to justify the use of genetic algorithms in the design of artificial dealers in an agent-based foreign exchange market. This study highlights the significance of the field study, an approach frequently used by sociologists, in agent engineering. The second one uses data from laboratories with human subjects. Examples abound. In Feltovich [2000], Tang [2003], and Arifovic & Ledyard [2004], different learning schemes were compared based on the results of human experiments. In economics, laboratory data are becoming increasingly available from the study of *Experimental Economics* and *Behavioral Economics*. When data from field studies, surveys or censuses become difficult to obtain, it is inevitable for economists to use the second type of data to conduct research. This approach is known as the *Lucas criterion* (Lucas [1986], Chen & Yeh [1996]). Lucas criterion suggests that a comparison of the behavior of adaptive schemes with behavior observed in laboratory experiments involving human subjects can facilitate the choice of a particular adaptive scheme.

There are already many studies that have grounded their agent engineering in the spirit of *Lucas criterion*. For example, Arifovic [1994] used two versions of the genetic algorithm (*basic GA* and *augmented GA*) to implement agent engineering. She

³ The KISS principle was first proposed in Axelrod [1997]. It stands for “*Keep it simple, stupid.*”

⁴ Computational intelligence is a new development paradigm of intelligent systems which has resulted from a synergy between fuzzy sets, artificial neural networks, evolutionary computation, and machine learning, etc. (Chen & Wang [2003]). All of these techniques have been applied to modeling agents in the economic literature; see Chen [2002a], Chen [2002b], and Brenner [2006] for a glossary of them.

reported that the simulation results from the basic GA showed that individual quantities and prices exhibited fluctuations over the entire duration and did not result in convergence to the rational expected equilibrium values, which was inconsistent with the experimental results involving human subjects. By contrast, the results of the augmented GA exhibited convergence to the rational expected equilibrium values, and were able to capture several features of the experimental behavior of human subjects better than other simple learning algorithms. According to Lucas criterion, the augmented GA was justified as an appropriate adaptive scheme.⁵

In addition to Lucas criterion, empirical evidence from experiments has been used to examine whether reinforcement learning adequately describes the way people behave. For example, Feltovich [2000] gives an evaluation of reinforcement learning versus some of its competitive alternatives, such as *direction learning* and *belief learning*, in experimental asymmetric-information games.

The purpose of this paper is two-fold. First, we will address the question: *to what extent can experimental economics or behavioral economics help build agent engineering? Does the proposed guideline really have a solid foundation?* Our assertion is that experimental economics and behavioral economics have their limits and cannot solve the foundation issue of agent engineering. The published guideline therefore requires revision. In this paper, we shall argue that computational equivalence (CE) is the direction in which to go.

Then, the second issue addressed by the paper, in light of the proposed computational equivalence principle, is *the relevance of computational intelligence*. While CI has already been extensively used in agent engineering, objections to or scepticism regarding the use of CI techniques still exist. We shall argue, in this paper, that most objections originate from neglecting the CE principle. As Simon [1996] observed, paper and pencils are tools that give bounded-rational agents more memory power. So is CI, which serves as a decision-support device to help bounded-rational agents deal with complex surroundings. Accordingly, the relevance of CI should not be based on its prediction of the outcomes of human experiments alone, but on its penetration rate *when they are available for human subjects*. A setup for a laboratory that satisfies the computational equivalence condition, called the CE Lab, is, therefore, proposed to examine the relevance of CI. The lab may further extend our analysis and understanding of human adaptive behavior under consideration to the computational capacity imposed upon humans.

The remainder of the paper is organized as follows. Section 2 introduces the computational equivalence principle as a foundation of agent engineering. Section 3 presents the idea of a lab, called the CE lab, which satisfies the computational equivalence condition. As an illustration, Section 4 states some common objections

⁵ For more applications of the Lucas criterion to justify the use of the GA or some of its specific versions, the interested reader is referred to Arifovic [1995] and Arifovic & Maschek [2003].

to the use of CI techniques and shows how the proposed CI principle can overcome these objections. Section 5 addresses the research questions that can be dealt with using the CE lab. The concluding remarks are presented in Section 6.

2 Computational Equivalence

The idea of the computational equivalence principle was motivated by Herbert Simon, the 1978 Nobel Laureate in Economics. In proposing bounded rationality, Simon took into account the cognitive limitations of the decision maker – limitations of both knowledge and computational capacity (Simon [1997]). In a simple psychological study on concept attainment, Gregg & Simon [1979] designed an experiment with human subjects. The experiment was designed with limited dimensions so that the number of trials a subject needed to discover the answers could, provided that the subject used the most efficient discovery strategy, be estimated *a priori*. With such a simple design, Simon stated that if sufficient time were allowed for each trial and if the subject were provided with paper and pencils, any subject of normal intelligence could be taught to follow this most efficient strategy and would do so without much difficulty. However, Simon thought that when subjects were asked to respond in just a few seconds and also without facilities such as paper and pencils, they would be unable to apply the efficient strategy (Simon [1996]).

The lack of facilities and the limited reaction time are important sources of the bounded rationality of human beings. Computational intelligence tools function as “advanced” paper and pencils, and they may cause agents to make decisions differently or, sometimes, more effectively. Agent-based computational economics may help predict the market outcome when agents are well equipped with such “paper and pencils.” Nonetheless, whether or not agents would like to use such “paper and pencils” is an empirical issue which needs to be addressed in the context of experimental economics. However, this idea has not been well acknowledged in experimental economics as it currently stands.

Our departure is, therefore, based on the rationale that different learning algorithms require different *computational resources* and that difference, to the best of our knowledge, has not been addressed in the experimental design that includes human subjects. As a result, the claim that an adaptive scheme (generated by one type of learning algorithm) is superior over others (generated by other types of learning algorithm), based on their simulation results, is not always valid. One scenario can be that the adaptive schemes become unavailable to human subjects due to the lack of high-performance computing facilities required by the adaptive schemes. Another scenario is for on-line transaction experiments where a very limited amount of time is allocated to the agents (human subjects) to process the data before making a decision. Such a constraint makes it impossible for the human agents to carry out computationally-intensive adaptive schemes, such as *genetic programming* or

fuzzy neural networks. Without considering the issue of computational resources, any comparative study based on experimental results may be biased.

Let us take the *double-auction experiment* as another example. In this auction, both sellers and buyers submit bids which are then ranked from the highest to lowest to generate demand and supply profiles. Based on the profiles, the maximum quantity exchanged can be determined by matching selling offers (starting with the lowest price and moving up) with demand bids (starting with the highest price and moving down). Experiments based on double auction have a long history in experimental economics (Smith [1991]). While the experiments involving human subjects started 40 years ago, serious work on agent engineering is only just beginning. The zero-intelligence (ZI) trader was introduced by Gode & Sunder [1993]. It was then extended into the zero-intelligence plus (ZIP) trader by Cliff [1997]. More sophisticated agents based on human-written programs were considered by Rust et al. [1993] and Rust et al. [1994], which also motivated Chen & Tai [2003] to use genetic programming to make traders autonomous. Another related study is that by Dawid [1999] who used the genetic algorithm to evolve traders. Given such a variety, can we answer which one provides better agent engineering in light of the experiments conducted by Smith [1991]? Can the experimental economics of the 1970s and 1980s resolve the selection issue?

Clearly not. ZIP, GA and GP differ in their required computational resources. Consequently, as mentioned above, in a computationally-poor environment, it is not surprising to see that the behavior of human subjects is quite similar to the agent-based simulation using simple heuristics, such as the *ZIP Plus* scheme, and may be quite distinctive from the one using genetic programming. However, that result alone cannot effectively lend support to the superiority of *ZIP Plus* over GP. Without knowing this critical relation, experiments involving human subjects would simply be too arbitrary to be a foundation of agent engineering. Unfortunately, this subtle point has not received sufficient attention on the part of either experimental economists or agent-based computational economists.

Experimental economics was developed in an age where decision supports provided by intensive computation were not available, whereas agent-based computational economics was cultivated in an era accompanied by increasing efficiency in terms of both software and hardware. This sharp difference in computational background does not make the use of the former as the foundation of the latter as obvious as one might have thought initially. To address the pivotal questions, such as whether genetic algorithms (or any other CI tools) represent an essential learning process regarding the past of humans, the laboratory involving human subjects must be upgraded to such a degree that GA (or any other CI tool) can be effectively executed for human subjects. We shall call this condition *computational equivalence*. In other words, *unless the condition of computational equivalence is satisfied, experimental economics cannot serve as a way of defining a principle of agent engineering*. It is misleading to claim the superiority of one adaptive scheme over

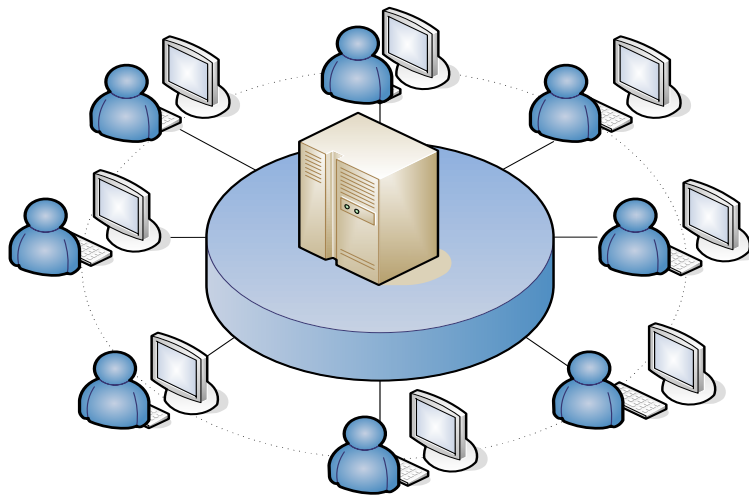

Fig. 1. A Web of the CE Lab

In the CE laboratory, each human participant will be connected to the “society” through a personal computer (client) and the server. The interactive dynamics of all participants then takes place through the web.

another simply by citing the experimental results observed in the laboratories which are not computationally equivalent.

3 Computational Equivalence Laboratory

Given the discussion above, we propose a computer laboratory which is built in line with the condition of computational equivalence. In this laboratory, all human subjects can *choose* to follow any adaptive scheme (CI tool) which is already installed in the lab and is made available to the end users. Of course, they can also choose their own preferred ways of making decisions, e.g., relying on their simple heuristics, if they fail to see the benefits of using the sophisticated adaptive schemes. The whole idea is depicted in Figures 1 to 3.

The whole laboratory is webbed by a network as shown in Figure 1. This web provides the basic platform for running experiments involving human subjects. Each human subject (real agent) is connected to at least one computer (*client*). The participation of the real agents in the experiments, e.g., through submitting a limit order in a stock market experiment (Smith et al. [1988]), proceeds via the client to the *server* and further to the whole web. Figure 2 is an expanding picture of what the human subject can see from his/her computer screen. Via this client machine, the real agent can acquire all the information pertinent to the experiment. The real agent may not have direct eye contact with other real agents since these clients are not necessarily located in the same room. Nonetheless, in the case where these clients are distributed in different places, real agents may still have eye contact with

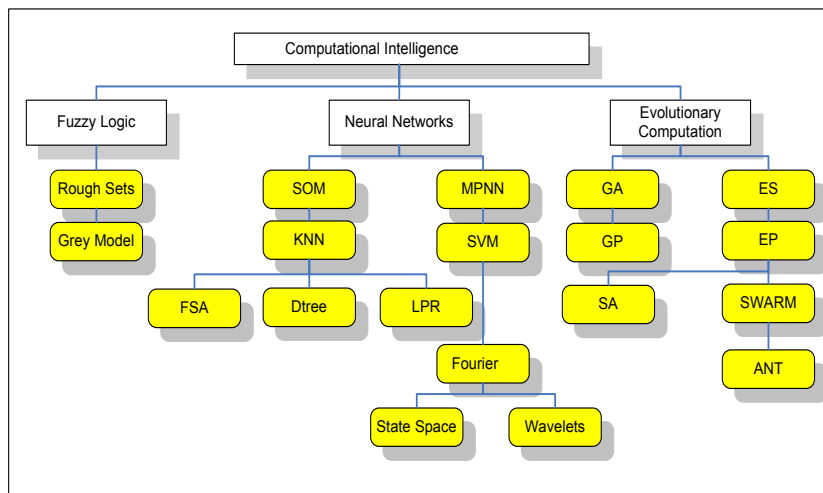

Fig. 2. Menu of Adaptive Schemes (CI Tools)

CI tools are made available for each human agent. From the computer screen, each human agent can choose his/her favorite adaptive scheme to learn from and adapt to the surrounding environment. The screen is presented to them in a very friendly manner. In this case, different classes of CI tools are grouped in an organization chart. See Chen & Wang [2003] for more details of this proposed taxonomy of CI.

other participants via the attached camera.⁶

The idea of *computational equivalence* is exemplified in Figures 2 and 3. In addition to the basic information provided by the experiment, the client also provides real agents with a computationally-rich environment such that the agents are able to perform some non-trivial computation before they finalize their decision. Here, real agents can make their choice of the adaptation scheme that they would like to follow. For example, in the context of the double auction experiment, they can follow the GA to submit a bid or ask. If they *all* make such a choice, then the market dynamics will be pretty much similar to what Dawid [1999] predicted. They can also follow the GP to learn a trading strategy first, and based on that strategy submit a bid or ask. Again, if they *all* make such a choice, then the market dynamics will be close to what Chen & Tai [2003] predicted. Of course, there is no reason why they should all choose the same adaptive scheme, as each can make a choice independently from the menu shown in Figure 2.

Additionally, one recent research trend in computational intelligence involves the extensive use of hybrid systems, in which many tools work synergetically together as a *multi-agent system*. The CE lab also allows participants to organize their own hybrid systems from a set of CI tools. For example, a genetic neural fuzzy system (Ringhut & Kooths [2003]) is shown in Figure 3.

⁶ To the best of our knowledge, experiments relying on eye contact are very limited. One of the examples is the famous *ultimatum game*. (Güth et al [1982], Hoffman et al. [1996])

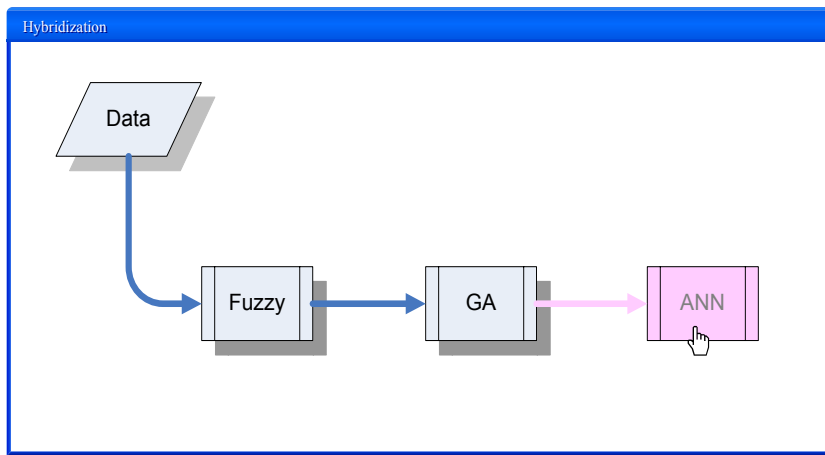

Fig. 3. Advanced Menu of Adaptive Schemes (CI Tools)

A human agent may combine several different CI tools into a hybrid system to learn and adapt. For example, a genetic neural fuzzy system is shown here.

There are two important issues when human agents are presented with the adaptive schemes as shown in Figure 2. The first one is the provision of performance indicators of adaptive schemes. Because agents, be they human or artificial ones, are goal-driven, they have to be provided with performance indicators whenever they are going to make decisions. For example, in a stock market experiment, each human agent is allowed to choose among, say, 5 adaptive schemes. Each time he/she follows a specific algorithm and sends the orders to the market, there is no problem that he/she will know the performance of his/her decisions. But considering the other 4 adaptive schemes left unchosen, there are two possible arrangements. In the first case, each adaptive scheme is assigned a performance indicator, e.g., profit earned in the last trading round, in a best-response fashion. Thus real agents can easily compare different adaptive schemes and choose among them. In the second case, only the scheme chosen by the human agent in this round is assigned a performance indicator. Making a decision in this setting is not as easy as in the previous one, but this setting is more realistic, especially when the target market of the research is an electronic market as mentioned in Section 5.3.

The second issue that should be fairly contemplated is whether human agents are familiar with the CI techniques presented. Aside from the practical difficulties in gathering experienced subjects or training inexperienced ones, this issue is rather interesting because of the role reasoning might play in the human decision process. When the limitations on computational capacity are largely removed, and when human agents are facing an abundance of alternative adaptive schemes, what will they choose? Are reasonableness, semantics, and comprehensibility crucial criteria for human agents when choosing among CI techniques? Or will human agents simply choose the one that performed best regardless of whether they are familiar with it or not? This is a question that can only be answered empirically in the CE lab.

4 Computational Equivalence and the Selection of Adaptive Algorithms

Now, we can define what *computational equivalence* means. For an agent-based computational model, if each of the human agents behaves by *choosing exactly the same* form of agent engineering as the model suggests, then the experimental results, either individual or aggregate, will be the same as the agent-based simulation results, at least in a statistical sense. In other words, in a way quite different from the current directional relationship between experimental economics and agent-based computational economics, we are not only interested in replicating experimental results based on agent-based simulations, but what we have also said here is that agent-based simulation results can also be replicated by experiments if the “right” form of agent engineering is chosen by the human subjects in the experiment. This is the essence of *computational equivalence*.

The contributions of computational equivalence to complex adaptive economic systems are two-fold. *First*, it provides a *competing explanation* for the failure of some adaptive schemes to replicate the experimental results. In the past, such failures would usually be largely attributed to the irrelevancy of the chosen adaptive schemes. However, a competing explanation nowadays is that the laboratory is not well designed to satisfy the CE condition. Had it been so, those adaptive schemes might have proved their relevance in describing how humans behave. *Second*, through the CE lab, we can see that the agent-based computational economic model is no longer just a theoretical representation of the reality, but it can also serve as a blueprint for an economic system to be realized in the future. For example, the model of Kirman & Vriend [2001] is not just an agent-based simulation of the fish market. If the fish market somehow becomes automated one day in the future and all market participants can get access to a computationally-rich environment to form their decisions, then the model of Kirman & Vriend [2001] can be considered to be a blueprint of the real fish market.

Let us elaborate on the first point above using the example of *genetic programming*, one of the very popular CI tools. The following is a list of criticisms voiced by the journal referees on several of the uses of genetic programming in agent-based computational economics. For the convenience of discussion, they are numbered as follows:

- (1) One can see why genetic programming (an extension of genetic algorithms) might work for computer problem-solving. However, genetic programming is not well grounded in considerations of human behavior.
- (2) There just isn't sufficient justification in the paper to support the view that what we have is a model for a population of agents learning over time (if they seriously wanted to push this view they would, for instance, need to tell readers how to interpret the cross-over operation).
- (3) The regular GP representation and presence of operators often lead to overly

complex and unreliable solutions. Such solutions, comprised of complex combinations of functions and indicators, have often been difficult to understand and interpret. Deciphering the winning programs might be an impossible task in many applications. It might be impossible to use these rules in order to understand the process by which humans behave. The usefulness of the GP method for fundamental research thus seems quite restricted *a priori*.

As we shall argue here, none of these arguments is true when computational equivalence is imposed. Objection (1) is the most general type of criticism. It is true that, up to the present, genetic programming is not well grounded in considerations of human behavior, but the main reason for this is that we do not have a lab which can make it easier for human subjects to use GP in forming decisions.⁷ As was discussed before, GP is a highly computationally-demanding CI tool. How can we expect human subjects to seriously base their decisions on GP without first reducing their computational load to a reasonable degree? So, clearly, Objection (1) cannot be valid because it violates the computational equivalence condition.

Objection (2) is also similar to Objection (1), but is more technical-oriented. This kind of comment is frequently made in relation to other CI tools. In general, this means that a CI tool cannot be regarded as a sensible human learning and adaptation process if its major operator, e.g., the *cross-over operator* in GP, is empirically not analogous to human behavior. Without acknowledging computational equivalence, this argument is also misplaced. Whether or not a CI tool can be an effective description of human behavior has nothing to do with whether the society has an innate sense of that operator. On the other hand, managers who use GP to make predictions may not need to be convinced that its technical operators have empirical social meaning.⁸ As long as human behavior is concerned, the key issue is whether they would *believe* that GP can enhance their quality decisions. This is an empirical question, and can only be solved with a lab based on computational equivalence. A full understanding of its technical details may be neither a necessary nor a sufficient condition for the formation of this belief.

Just as in the case of Objection (2), Objection (3) proposes another possible reason why people may not use GP. This criticism is commonly shared in relation to other CI tools characterized by complex and nonlinear behavior. Our response to Objection (3) is similar to that to Objection (2). Whether or not a comprehensive understanding is crucial for humans to accept a state-of-the-art technology can only be answered empirically. It is quite common in behavioral economics for human

⁷ The leading GP expert, John Koza, has reacted to this criticism by pointing out that the structure and function of the human brain is nothing simple and comprehensible. Maybe one day, *neural economics*, a recently emerging field, may shed light on the foundation of genetic programming or artificial neural nets as the real foundation of human behavior (Glimcher & Rustichini [2004], Camerer et al. [2005], Rustichini [2005]).

⁸ An interesting example can be found in Caplan & Becker [2004], which shows the process of convincing the CEO of the company to implement a GP-based investment project.

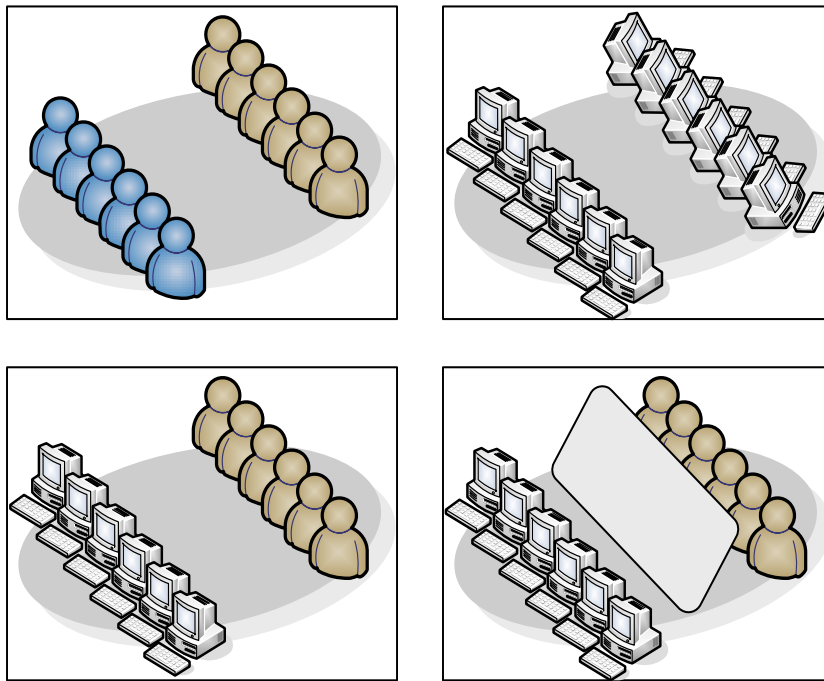

Fig. 4. Complex Systems Composed of Human and/or Software Agents

choices to not necessarily be rational or scientific. Various biases have been well established empirically in behavioral economics.

To sum up, the relevance of computational intelligence to human adaptive behavior cannot be appropriately studied without a CE laboratory (a lab that satisfies the computational equivalence condition).

5 Research Questions Driven by the CE-Lab

The CE Lab is not designed only for specific applications; its framework is very general so that we can use it to address a very fundamental question: *What will happen when the participating human agents are equipped with CI tools in a complex adaptive environment?* We will try to elaborate on this question by using a picture. Figure 4 gives four different types of agent-based models. On the left of the top row, we have an agent-based model that is completely composed of human agents. On the right of the top row, we have a model that is purely composed of software agents. Two models on the bottom are agent-based models that are composed of both human and software agents. The difference between the two is that human agents on the left model are aware of the existence of software agents while the human agents on the right model are not.

The CE lab enables us to conduct experiments based on the four different types of agent-based models and hence makes it possible for us to perform a compara-

tive study on the complex dynamics of the four agent-based models. Moreover, in addition to the comparative study, the CE lab also allows us to examine the possible *structural changes* or *regime changes* when a society that is solely composed of human agents is gradually or suddenly transforming itself into a society with a mixed population of software agents and human agents. The main points of interest are as follows:

- First, in general, how do humans react to the nonlinear complex dynamics? Would they tend to behave in a more complex manner when situated in such a complex environment?
- Second, if they do behave in a more complex manner,⁹ what are the consequences of such behavior? Will the aggregate dynamics become more (or less) complex and nonlinear?
- Third, what are the additional impacts of the inclusion of artificial agents (human agents) on an already-existing society composed of only human agents (artificial agents)? Do artificial agents on markets influence human behavior? (Grossklags & Schmidt [2003])

These three issues will be elaborated separately below.

5.1 Behavioral Complexity

Regarding question (1), an interesting hypothesis is that humans may not necessarily respond to a complex environment with complex behavior. On the contrary, they may just follow a *rule of thumb*. This *simplicity hypothesis* is partially supported by some theoretical and empirical work.¹⁰ For example, the winning strategy in a trading tournament involving many agents is simple (Rust et al. [1993; 1994]). In trading, the simple trading strategy *buy-and-hold* was found to exhibit superior performance to many other sophisticated strategies. In making predictions, the simple predictor *random walk* was also shown to predict more accurately than other sophisticated predictors. Nonetheless, these findings are not strong enough to discourage people from devoting a great deal of effort to developing sophisticated nonlinear predictors as well as trading strategies. Therefore, what determines people's search intensity for a "best" perception (representation) of complex nonlinear phenomena remains an interesting issue.

Through these experimental designs and the associated agent-based simulations of the CE lab, we can watch and study how human agents react to a complex nonlinear environment. In particular, this helps us to understand under what circumstances

⁹ For example, they incorporate some of the CI tools into their decisions.

¹⁰ This hypothesis can be loosely connected to the famous *Occam's razor* or the *parsimony principle*.

human agents tend to behave in ways that are more complex than simple.¹¹ More generally, can we find an effective characterization or implicit constraint of agents' choices of adaptive schemes? For example, we need to ask whether they tend to prefer qualitative schemes over quantitative schemes, linguistic schemes over crisp schemes, and simple (comprehensible) but sub-optimal schemes over complex (incomprehensible) but accurate schemes, etc. We believe that these are important questions that need to be addressed before we can lay a solid foundation for agent engineering.

One important recent development in agent-based social simulation has occurred in the use of *natural language* (Lindström [1998], He et al. [2002], Tay & Linn [2001]). People frequently and routinely use natural language or linguistic values, such as high, low, and so on, to describe their perception, demands, expectations, and decisions. Some psychologists have argued that our ability to process information efficiently is the outcome of applying *fuzzy logic* as part of our thought process. Evidence on human reasoning and human thought processes supports the hypothesis that at least some categories of human thought are definitely fuzzy. Yet, early agent-based economic models have assumed that agents' adaptive behavior is *crisp*. Tay & Linn [2001] made progress in this direction by using the *genetic-fuzzy classifier system* (GFCS) to model traders' adaptive behavior in an artificial stock market. Tay & Linn [2001] provided a good illustration of the *non-equivalence* between the acknowledgement of the *cognitive constraint* and the assumption of *simple agents*. It is well-known that the human mind is notoriously bad at intuitively comprehending exponential growth. However, there is no evidence that traders on Wall Street are simple-minded. Tay & Linn [2001] recognized the difference, and appropriately applied the GFCS to *lessen* the agents' reasoning load via the use of natural language.

5.2 *Micro-Macro Relationship*

The thing that concerns the second issue is the casual relationship between the complexity of macro dynamics and the complexity of micro dynamics, or simply the *emergent phenomena*. While a series of studies regarding the emergent phenomena were conducted in the past in the ACE context (Franke [1998], Chen & Yeh [2002], Chen & Liao [2004]), there is also no empirical evidence in relation to experimental economics.

A particularly interesting thing is that the micro behavior can sometimes be quite different from the macro behavior. Both the work done by Franke [1998] on the cobweb model and by Chen & Yeh [2002] on the asset pricing model has shown

¹¹ While Chen & Yeh [2001] simulate the evolving complexity of software agents in the artificial stock markets, the empirical counterpart of human behavior is not available in the literature. The establishment of a CE Lab would help.

that the time series of the market price (an aggregate variable) follows a simple stochastic process. However, there is no simple description of the population dynamics of individual behavior. The simple stochastic price behavior was, in effect, generated by a great diversity of agents whose behavior was constantly changing. Chen & Yeh [2002] proposed a measure for the *complexity* of an agent's behavior and a measure of the *diversity* of an agent's complexity, and it was found that both measures can vary quite widely, regardless of the simple aggregate price behavior.

In addition, using micro-structure data, Chen & Liao [2004] initiated an approach to study the *emergent property*. Based on that definition, they found that a series of aggregate properties, such as the efficient market hypothesis, the rational expectations hypothesis, the price-volume relation and the sunspot effect, which were proved by rigorous econometrics tests, were generated by a majority of agents who did not believe in these properties. Once again, our understanding of the micro behavior does not lead to a consistent prediction of the macro behavior. The latter is simply not just the linear scaling-up of the former. Conventional economics tends to defend the policy issues concerned with the individual's welfare, e.g., the national annuity program, based on the macroeconomic tests, e.g., the permanent income hypothesis. Agent-based macro-economics may invalidate this approach due to emergent properties.

By using the CE lab, one can vary the computational resources under different experiments. For example, in one experiment, human agents are exposed only to simple adaptive schemes, whereas in the others they can gain access to sophisticated adaptive schemes. In this way, we can examine whether a society of naive agents will tend to result in less complex aggregate dynamics than a society of sophisticated agents.

5.3 *Interactions between Human Agents and Software Agents*

Most experimental economic models only consider human agents, whereas most agent-based computational models only have software agents. While the original motivation of agent-based models has been to understand the equivalent systems composed of human agents, human participation and interface with the system and with the artificial agents have been excluded. In other words, human agents have been completely replaced by artificial agents.¹² Recently, the literature has started to look at the issue of interaction between software agents and human agents in complex adaptive systems, such as auction games (Das et al. [2001], He et al. [2002], Grossklags & Schmidt [2003], Shachat & Swarthout [2002], Wellman et al.

¹² Having said that, we would like to point out that the modern definition of artificial intelligence has already given up on the dream of replicating human behavior. Now, a more realistic and also interesting definition is based on the *team work* cooperatively performed by artificial agents and human agents (Lieberman [1996]).

[2002]), oligopoly games (Midgley et al. [1997]) and the stock market (Kurumatani et al. [2005]). Nonetheless, in these setups, human agents are only exposed to limited computational resources, and are not equipped with high-performance computing; therefore, the potential feedback relationship between human agents and the system, including the artificial agents, has not been greatly exploited. We believe that the CE lab is the first step toward a formal study of the fundamental question posed above.

The third issue in a sense concerns the effects of the appearance of software agents on human agents. When human agents are explicitly informed of the presence of anonymous software agents in the system, would they behave differently as compared to the case where such a presence is uncertain (Grossklags & Schmidt [2003])? Furthermore, when human agents are provided with more detailed information regarding how software agents behave, such as their adaptive schemes, would that affect their own choice of adaptive schemes? This question is particularly relevant for electronic trading systems, such as *ebay*. In a sense, this question can be viewed in terms of the *socio-psychological impact* on human behavior in the presence of interacting machine intelligence. An equally important issue is concerned with the associated market dynamics and efficiency (Chen & Tai [2003]).

The CE lab described above not only serves as a starting point toward a foundation of agent engineering but also functions as a platform to study the behavior of *electronic markets*. In this type of market, all decisions are either made by humans aided by software or are automated completely. The former is exactly the architecture depicted in Figure 4, whereas the latter is equivalent to a CE lab where all human agents are replaced by software agents as shown in the same figure.

There are already many economic and financial applications of these two types of architecture. For example, in Internet auctions, software agents, such as *esnipe* and *auctionblitz*, support human bidders with routine tasks to improve performance precision (Ockenfels & Roth [2002], Roth & Ockenfels [2002]). Another example is in financial markets where programmed trades on the computerized trading platform can be used to help day traders in determining their bid and ask decisions (Varian [1988]). The CE lab can be viewed as a simple model of these complex adaptive systems, and, via agent-based simulation, can be used to enrich our understanding of this type of system.

6 Concluding Remarks

This paper has two aims. The first is to introduce a laboratory with human subjects, which satisfies the *computational equivalence* condition. The second is that the lab, referred to as the *CE lab*, can then serve as a platform to integrate the current research in experimental economics, behavioral economics (finance) and

agent-based computational economics. These three fields share a common research goal with regard to the relevance and significance of adaptive behavior to economic dynamics. While, from the perspective of agent-based computational economics, it is now quite clear that aggregate dynamics can crucially depend on the learning dynamics, the issue regarding the selection of the adaptation algorithms has not been effectively resolved. In particular, it cannot be resolved solely on the basis of experimental economics in the way Robert Lucas suggested. This is because most labs in which experiments involving human subjects are conducted do not provide subjects with high-performance computing facilities. Consequently, many adaptive schemes studied in agent-based computational economics are virtually impossible for human agents to compute, and the empirical relevance of adaptive schemes such as fuzzy logic, neural networks, and genetic algorithms is beyond the current research capacity of experimental economics.

Computational equivalence is about *replicability*. It basically requires that the lab have the same computational power as ACE generally has. To achieve this goal, software agents are introduced to and work with human agents in the lab, as suggested by the MIT approach (to artificial intelligence). By means of computational equivalence, what is done by the software agents (autonomous agents) in ACE may in principle be replicated by human agents in this lab. Only when replicability is guaranteed, can one ground the foundation of agent engineering in experiments involving human agents.

Leaving aside ACE, the failure to incorporate these computational intelligence techniques into the current experimental economics naturally limits the computational complexity of human decision rules. This limitation can be a real concern when the human behavior which experimental economics tries to study is largely inspired by a computationally-rich environment. Specifically, in an era of electronic commerce, when more and more automated trading techniques are being made available to human agents, questions regarding the dynamics and the efficiency of different auction designs may no longer be properly answered by the experiments conducted in the conventional lab. However, the use of the CE lab would help. Furthermore, more intriguing questions may arise when human agents do not only interact (play, compete) with human agents, but also with the possible presence of software agents, as is often seen in the case of eBay or Nasdaq. What are the impacts of software agents on human agents? What is the effect on market dynamics and efficiency when autonomous agents are introduced to the markets? More generally, how do human agents adapt to their digital surroundings and what are the consequential dynamics? The CE lab, by effectively integrating ACE and experimental economics, provides us with a starting place to explore the richness of the nonlinear complex digital economy.

Acknowledgements

An earlier version of this paper was presented at the *10th International Conference on Computing in Economics and Finance* held in Amsterdam. The authors greatly benefited from the interaction with conference participants. The authors are also grateful for research support in the form of NSC grant No. NSC. 93-2420-H-004-003 and No. NSC. 94-2415-H-004-003 in support of the idea of the CE Lab as proposed in this paper. The current version of the paper has also benefited from a very carefully written report by an anonymous referee, to whom the authors are most grateful.

References

- Arifovic, J. (1994), "Genetic Algorithm Learning and the Cobweb Model," *Journal of Economic Dynamics and Control* **18**(1), pp. 3–28.
- Arifovic, J. (1995), "Genetic Algorithms and Inflationary Economies," *Journal of Monetary Economics* **36**(1), pp. 219–243.
- Arifovic, J., and J. Ledyard (2004), "Scaling Up Learning Models in Public Good Games," *Journal of Public Economic Theory* **6**, pp. 205–238.
- Arifovic, J., and M. Maschek (2003), "Expectations and Currency Crisis—An Experimental Approach," paper presented at the *9th International Conference on Computing in Economics and Finance*, University of Washington, Seattle, July 11–13.
- Axelrod, R. (1997), "Advancing the Art of Simulation in the Social Sciences," in R. Conte, R. Hegselmann, and P. Terna (Eds.), *Simulating Social Phenomena*, Lecture Notes in Economic and Mathematical Systems, pp. 21–40.
- Brenner, T. (2006), "Agent Learning Representation: Advice on Modelling Economic Learning," in L. Tesfatsion and K. L. Judd (Eds.), *Handbook of Computational Economics*, Vol. 2, North Holland, forthcoming in 2006.
- Camerer, C., G. Loewenstein, and D. Prelec (2005), "Neuroeconomics: How Neuroscience Can Inform Economics," *Journal of Economic Literature* **43**, pp. 9–64.
- Caplan, M., and Y. Becker (2004), "Lessons Learned using Genetic Programming in a Stock Picking Context," in U. O'Reilly, T. Yu, R. Riolo, and B. Worzel (Eds.), *Genetic Programming Theory and Practice II*, Springer, pp. 87–102.
- Chen, S.-H. (2001), "On the Relevance of Genetic Programming in Evolutionary Economics," in K. Aruka (Ed.), *Evolutionary Controversy in Economics towards a New Method in Preference of Trans Discipline*, Tokyo: Springer-Verlag, pp. 135–150.
- Chen, S.-H. (Ed.) (2002a), *Genetic Algorithms and Genetic Programming in Computational Finance*, Kluwer Academic Publishers.
- Chen, S.-H. (Ed.) (2002b), *Evolutionary Computation in Economics and Finance*, Physica-Verlag.

- Chen, S.-H., and C.-C. Liao (2004), "Agent-Based Computational Modeling of the Stock Price-Volume Relation," *Information Sciences* **170**, pp. 75–100.
- Chen, S.-H., and C.-C. Tai (2003), "Trading Restrictions, Price Dynamics and Allocative Efficiency in Double Auction Markets: Analysis Based on Agent-Based Modeling and Simulations," *Advances in Complex Systems* **6(3)**, 2003. pp. 283–302.
- Chen, S.-H., and P. P. Wang (2003), "Computational Intelligence in Economics and Finance," in Chen, S.-H. and P. P. Wang (Eds.), *Computational Intelligence in Economics and Finance*, pp. 3–55.
- Chen, S.-H., and C.-H. Yeh (1996), "Genetic Programming Learning and the Cobweb Model," in P. Angelino (Ed.), *Advances in Genetic Programming*, Vol. 2, Chap. 22. MIT Press, Cambridge, MA, 443–466.
- Chen, S.-H., and C.-H. Yeh (2001), "Evolving Traders and the Business School with Genetic Programming: A New Architecture of the Agent-based Artificial Stock Market," *Journal of Economic Dynamics and Control* **25**, pp. 363–393.
- Chen, S.-H., and C.-H. Yeh (2002), "On the Emergent Properties of Artificial Stock Markets," *Journal of Economic Behavior and Organization* **49**, pp. 217–129.
- Cliff, D. (1997), "Minimal-Intelligence Agents for Bargaining Behaviors in Market-based Environments," *HP Technical Report*, HPL-97-91, 1997.
- Das, R., J. Hanson, J. Kephart, and G. Tesauro (2001), "Agent-Human Interactions in the Continuous Double Auction," *Proceedings of the International Joint Conference on Artificial Intelligence*.
- Dawid, H. (1999), "On the Convergence of Genetic Learning in a Double Auction Market," *Journal of Economic Dynamics and Control* **23**, pp. 1545–1567.
- Duffy, J. (2006), "Agent-based Models and Human-subject Experiments," in L. Tesfatsion and K. L. Judd (Eds.), *Handbook of Computational Economics*, Vol. 2, North Holland, forthcoming in 2006.
- Feltovich, N. (2000), "Reinforcement-based vs. Belief-based Learning Models in Experimental Asymmetric-Information Games," *Econometrica* **68**, pp. 605–641.
- Franke, R. (1998), "Coevolution and Stable Adjustments in the Cobweb Model," *Journal of Evolutionary Economics* **8(4)**, pp. 383–406.
- Glimcher, P. and A. Rustichini (2004), "Neuroeconomics: The Consilience of Brain and Decision," *Science* **306**, pp. 447–452.
- Gode, D. K., and S. Sunder (1993), "Allocative Efficiency of Market with Zero-Intelligence Trader: Market as a Partial Substitute for Individual Rationality," *Journal of Political Economy* **101(1)**, pp. 119–137.
- Gregg, L.W., and H. A. Simon (1979), "Process Models and Stochastic Theories of Simple Concept Formation," in H.A. Simon, *Models of Thought*, Vol. I. Chapter 5.4. Yale University Press, New Haven, CT.
- Grossklags, J., and C. Schmidt (2003), "Interaction of Human Traders and Artificial Agents on Double Auction Markets: Simulations and Laboratory Experiments," in K. Chen, et al. (Eds.), *Proceedings of 7th Joint Conference on Information Sciences*, pp. 1269–1272.
- Güth, W., R. Schmittberger, and B. Schwarze (1982), "An Experimental Analysis of Ultimatum Bargaining," *Journal of Economic Behavior and Organization* **3(4)**,

- pp. 367-388.
- He, M., H.-F. Leung, and N. Jennings (2002), "A Fuzzy Logic-based Bidding Strategy for Autonomous Agents in Continuous Double Auctions," *IEEE Transactions on Knowledge and Data Engineering*.
- Hoffman, E., K. McCabe, and V. Smith (1996), "On Expectations and the Monetary Stakes in an Incomplete Information Ultimatum Game," *International Journal of Game Theory* **25(3)**, pp. 289–301.
- Holland, J., and J. Miller (1991), "Artificial Adaptive Agents in Economic Theory," *American Economic Review* **81(2)**, pp. 365–370.
- Izumi, K., and K. Ueda (2002), "Using an Artificial Market Approach to Analyze Exchange Rate Scenarios," in S.-H. Chen (Ed.), *Evolutionary Computation in Economics and Finance*, pp. 135–157.
- Kirman, A. P., and N. Vriend (2001), "Evolving Market Structure: An ACE Model of Price Dispersion and Loyalty," *Journal of Economic Dynamics and Control* **25(3-4)**, pp. 459–502.
- Kurumatani, K., H. Kawamura, and A. Ohuchi (2005), "Market Micro-Structure Analysis by Multiagent Simulation in X-Economy – Comparison among Technical Indices," *Information Sciences* **170(1)**, pp. 65–74.
- LeBaron, B. (2001), "A Builder's Guide to Agent-based Financial Markets," *Quantitative Finance* **1**, pp. 254–261.
- Lieberman, H. (1996), "Software Agents: The MIT Approach," Invited speech delivered at the *7th European Workshop on Modelling Autonomous Agents in a Multi-Agent World (MAAMAW'96)*, Eindhoven, The Netherlands, Jan 22–25, 1996.
- Lindström, T. (1998), "A Fuzzy Design of the Willingness to Invest in Sweden," *Journal of Economic Behavior and Organization* **36(1)**, pp. 1–17.
- Liu, J., Y. Y. Tang, N. Zhong, and P. S. P. Wang (2001), *Agent Engineering*, World Scientific Publishing.
- Lucas, R. E., Jr. (1986), "Adaptive Behavior and Economic Theory," *Journal of Business* **59**, pp. 401–426.
- Midgley, D., R. Marks, and L. Cooper (1997), "Breeding Competitive Strategies," *Management Science* **43(3)**, pp. 257–275.
- Ockenfels, A., and A. Roth (2002), "The Timing of Bids in Internet Auctions: Market Design, Bidder Behavior, and Artificial Agents," *Artificial Intelligence Magazine*, Fall, pp. 79–87.
- Ringhut, E., and S. Kooths (2003), "Modeling Expectations with GENEFER - An Artificial Intelligence Approach," *Computational Economics* **21**, pp. 173–294.
- Roth, A., and A. Ockenfels (2002), "Last Minute Bidding and the Rules of Ending Second Price Auctions: Evidence from eBay and Amazon Auctions on the Internet," *American Economic Review* **92(4)**, pp. 1093–1103.
- Rust, J., J. Miller, and R. Palmer (1993): "Behavior of Trading Automata in a Computerized Double Auction Market," in D. Friedman and J. Rust (Eds.), *The Double Auction Market: Institutions, Theories, and Evidence*, Addison Wesley. Chap. 6, pp.155–198.
- Rust, J., J. Miller, and R. Palmer (1994), "Characterizing Effective Trading Strate-

- gies: Insights from a Computerized Double Auction Market,” *Journal of Economic Dynamics and Control* **18**, pp. 61–96.
- Rustichini, A. (2005), “Neuroeconomics: Present and Future,” *Games and Economic Behavior* **52**, pp. 201–212.
- Shachat, J., and J. Swarthout (2002), “Procurement Auctions for Differentiated Goods,” IBM Watson Research Center Working Paper.
- Simon, Herbert A. (1996), *The Sciences of the Artificial*. Cambridge, MA: MIT Press.
- Simon, Herbert A. (1997), *Models of Bounded Rationality*, Vol. 3. Cambridge, MA: MIT Press.
- Smith, V. L. (1991), *Papers in Experimental Economics*, Cambridge: Cambridge University Press.
- Smith V. L., G. L. Suchanek, and A. Williams (1988), “Bubbles, Crashes, and Endogenous Expectations in Experimental Spot Asset Markets,” *Econometrica* **56(6)**, pp. 1119–1152.
- Tang, F.-F. (2003), “A Comparative Study on Learning in a Normal Form Game Experiment,” *Journal of Economic Behavior and Organization* **50**, pp. 385–390.
- Tay, N., and S. Linn (2001), “Fuzzy Inductive Reasoning, Expectation Formation and the Behavior of Security Prices,” *Journal of Economic Dynamics and Control* **25**, pp. 321–361.
- Tesfatsion, L. (1997), “How Economists Can Get Alive,” in B. Arthur, S. Durlauf, and D. Lane (Eds.), *The Economy as an Evolving Complex System, II*, Santa Fe Institute Studies in the Sciences of Complexity, Proceedings Volume XXVII, Addison-Wesley.
- Tesfatsion, L. (2001), “Introduction to the Special Double Issue on Agent-Based Computational Economics,” *Journal of Economic Dynamics and Control* **25(3-4)**, March 2001, pp. 281–293.
- Varian, H. R. (1988), “Effect of the Internet on Financial Markets,” School of Information Management and Systems, University of California, Berkeley.
- Wellman, M., A. Greenwald, P. Stone, and P. Wurman (2002), “The 2001 Trading Agent Experiment,” in *Proceedings of Fourteenth Innovative Applications of Artificial Intelligence Conference*, pp. 935–941.
- Wooldridge, M., and N. Jennings (1995), “Intelligent Agents: Theory and Practice,” *Knowledge Engineering Review* **10**, pp. 115–152.